



BANGERS – ‘BACK TO BASICS’ **2026 Rules, Regulations & Specifications**

Contents

| | |
|---|---|
| 1. THE FORMULA | 2 |
| 2. WHO CAN RACE | 2 |
| 3. WHAT TO DO NEXT | 2 |
| 4. ELIGIBLE CARS | 2 |
| 5. INITIAL PREPARATIONS | 3 |
| 6. PERSONAL SAFETY | 3 |
| 7. SAFETY EQUIPMENT | 4 |
| 7.1 CRASH HELMET | 4 |
| 7.2 RACING OVERALLS / GLOVES | 4 |
| 7.3 A NECK BRACE | 4 |
| 7.4 BALACLAVA | 4 |
| 7.5 WET WEATHER CLOTHING | 4 |
| 7.6 1kg FIRE EXTINGUISHER | 4 |
| 7.7 DRIVERS SEAT WITH HEAD RESTRAINT | 4 |
| 7.8 SAFETY HARNESS | 4 |
| 8. VIOLATIONS | 4 |
| 9. GENERAL RULES OF RACING | 4 |
| 10. DEMOLITION – TYPE EVENTS | 5 |
| 11. ROLL BAR | 5 |
| 12. BODYWORK | 6 |
| 13. WHEELS & TYRES | 6 |
| 14. EXHAUSTS | 6 |
| 15. BRAKES | 6 |
| 16. FUEL SYSTEM | 6 |
| 17. PAINTWORK | 6 |
| 18. SUN VISOR | 7 |
| 19. FIN PLATES | 7 |
| 20. DATA LOGGING | 7 |
| 21. VAN RULES | 7 |
| 22. SPECIFICATION & RULE CHANGES | 7 |
| 23. SEAT BELTS (ADDITIONAL TO ORCi DOCUMENTATION) | 7 |

1. THE FORMULA

This formula is designed as the entry level fun Banger class ideal for those just starting out or those drivers who want to race with a limited budget.

The object of the racing is to complete the specified number of laps in the shortest time. You may push a car from behind or spin a car to the infield but there is no following-in (you must not be on the back or side of a car as it hits the fence). 'T-Bones' are also not permitted (Section 9).

Racing is in a clockwise direction on a clearly defined circuit with a separate infield. Any wheels passing over the demarcation lines or entering on to the grassed infield areas will mean that the driver will be penalised.



2. WHO CAN RACE

This is a strictly limited contact formula aimed especially at novice drivers. All licence applications will be reviewed by the Promoter and it must be understood that applications may be refused if it is considered that the prospective driver is too experienced for this entry level formula.

Day licenses are available at a cost of £32 per meeting (inc. ORCi fund) – a temporary licence form must be completed in full.

3. WHAT TO DO NEXT

- Check through the fixture list for the 'Back To Basic' Banger fixtures and select a meeting or meetings.
- Contact the Stockcar Office via 01252 322920 to make your booking.
- Each booking is £20.00 per licenced driver or £32.00 per day licence driver including ORCi fund..
- When your booking has been processed you will be placed on to the booking system.
- On arrival at the Stadium you must first book in at the pit office and pay any fees applicable. By the act of signing-in to race, you are presenting your car as conforming to the rules.
- You must then get the car Safety Checked and obtain the Passed Safety check Sticker which has to be displayed in a prominent position on the car. The scrutineer will do a pre-meeting safety check, at any time during the meeting your car may be re-checked. If at this time your car fails scrutineer / safety checks the driver will be liable for punishment that could include a load-up or full ORCi ban.
- Ensure you are familiar with the raceway flags and the rules of racing, as you are now ready to race and will come under all the Rules & Regulations, similar to all the other formulae.

4. ELIGIBLE CARS

- Cars must be u1800cc. No Ford Mondeo, S/C MAX. No Non-Factory Limousines unless stated on the fixture list.
- Car Based 4x4 are permitted.
- No Left hand drive vehicles are permitted.
- Vans 'Back To Basics' (See section 20).

5. INITIAL PREPARATIONS

- Read & familiarise yourself with the Banger 'Back To Basic' Rules & Regulations for preparing the race car.
- Remove all exterior mouldings, screen glass, lamps, handles *and any spoilers*.
- Remove all *airbags and charges (if fitted)*, drivers side inner door handle & passenger seating.
- Remove the fuel tank, spare wheel carrier & tow bar if fitted.
- Remove rear spoiler even if factory fitted.
- Removed all tailgate / boot gas struts.
- All rear bumpers must be removed, the original front bumper maybe left on, but the outer plastic must be removed to just leave the 'under' bumper. No changing of bumpers during the meeting. NO New/Replacement bumpers on used cars. No wrapping of bumpers with tape or seat belt.
- It is compulsory to pad steering columns with **seat** foam if the original trim is removed.
- It is compulsory to pad the B pillar and roll cage **with seat foam**.
- Cars must remain 'on the key' with the original ignition system.
- Petrol pumps must be able to be turned off either by the ignition key or a battery cut-off switch.
- Radiators must be left in the original position all times and replacement radiators must be in the same original place.
- Batteries may be left in the original position but if moved inside the car must be securely fastened and covered.
- Original fuel lines may be used but must enter the car either through or as near to the bulk head as possible.
- The lower edge of the front wings may be trimmed **or cut** but wings must not be folded or crimped.
- Bonnets can be tied down with seat belt only in a maximum of four separate places.
- Boots/hatchbacks maybe be tied shut with seat belt only in two separate fixings. You must remove tailgate gas struts.
- Passenger doors may be tied shut with seat belt in a maximum of two separate places which must not go through the roof or the floor. Any seat belt must be knotted and not fixed with tape or tex screws. **Drivers door maybe taped shut**.
- No **additional** welding is permitted.
- **Seat belts can be fitted using chain, the chain must be at least 8mm thick & be solid links**
- Apart from items mentioned within these rules all other parts must remain standard as manufactured.

6. PERSONAL SAFETY

Drivers are advised that under Health & Safety, they are responsible for their own and their Mechanic's actions. Promoters have had complaints made about Registered Drivers & also Mechanics, consuming large amounts of alcohol at meetings, which could effect their judgement or be detrimental to their health, when medical attention has to be administered by Paramedics, St Johns or Hospital Staff.

Should an incident occur that proves fatal on the raceway and you are involved, it is likely that the Police will want interview you. If you drive, don't drink! Scrutineers and Officials will report to the Clerk of the Course, anybody they believe is under the influence of Drink or Drugs.

Drivers who are thought to be under the influence, may be breathalysed.

Flags as used by the Starting Marshall & Trackside Safety Staff.

- Waved Green Flag – Go, the race has started.
- Waved Red Flag – Stop racing, slow down and stop immediately.
- Chequered Flag – The race winner has crossed the line, continue to race until the Red Flag is shown.
- Held Yellow Flag – Beware, you are approaching a hazard on the track, continue to race with caution.
- Waved Yellow – Slow down, hold your position, and do not overtake any other cars. The pace car is entering the circuit to control the pace until the raceway is clear to race.
- A Blue Flag – The race has become processional, you may not pass another driver without attempting to spin them out.
- Black cross on a White board – You have committed an infringement and may be penalised in the results.
- Waved Black Flag - You are disqualified, pull off the track immediately.
- White Flag with a Red Cross – Technical Disqualification, leave the track immediately.

Drivers are also reminded that they should line up on the grid with their engines switched off in the correct points order, unless told otherwise.

7. SAFETY EQUIPMENT

7.1 CRASH HELMET

Please visit the ORCi website www.orci.co.uk for current safety equipment regulations.

7.2 RACING OVERALLS/GLOVES

Please visit the ORCi website www.orci.co.uk for current safety equipment regulations.

7.3 A NECK BRACE

Please visit the ORCi website www.orci.co.uk for current safety equipment regulations.

7.4 BALACLAVA

Please visit the ORCi website www.orci.co.uk for current safety equipment regulations.

7.5 WET WEATHER CLOTHING

Please visit the ORCi website www.orci.co.uk for current safety equipment regulations.

7.6 1kg FIRE EXTINGUISHER

Please visit the ORCi website www.orci.co.uk for current safety equipment regulations.

7.7 DRIVERS SEAT WITH HEAD RESTRAINT

You must have a Driving Seat with a head restraint. The seat should occupy its original position where possible.

7.8 SAFETY HARNESS

Please visit the ORCi website www.orci.co.uk for current safety equipment regulations.

8. VIOLATIONS

- When referring to the engine, gearbox, final drive, mechanical or construction Rules & Regulations, the principle will always be: *Unless permission is specifically granted to make modifications (or any variation) nothing may be done to alter or change the Standard Parts in any way.*
- It is the responsibility of the Driver to prove to the Promotion that the part is legal, by way of written proof of where the part originated. This must be undertaken within 7 days, otherwise the item in question will be deemed illegal, resulting in immediate suspension from racing & referral for disciplinary action. Unless the rules say you can do it, you cannot do it!
- Presentation of a Vehicle for Safety Check / Scrutineering is a declaration by the entrant that the vehicle is eligible for that event.
- Car engines & fuel will be checked on a random basis. Violations or refusal to allow an engine check will result in an immediate suspension of all racing facilities.
- All Car and Engine Specifications will be taken from either the manufacturers Technical Specifications or the Technical Service Data books as published by Glass's Guide.
- Should a discrepancy occur between the Specifications then the Promotion will exercise its judgement, and that decision will be final.
- Clarification on any one item may be sought from the Promoter.
- Each driver is permitted one car per meeting & each car is permitted one driver per meeting.

9. GENERAL RULES OF RACING

- You must line up in your grid positions with the engine switched off.
- Grid positions will be allocated on a first come first served basis on track. Race winners will start at the back of the grid for the rest of the meeting. If it is a points series meeting then the top 3 of the points series will start from the back of the grid.
- The definition of a 'T-Bone' is when contact is made with the side of a car between the front and rear wheels. T-boning cars which are against or close to the barrier with excessive force is not

allowed. It is also not permitted to t-bone a car which is close enough to the barrier to mean that significant impact with the barrier is inevitable after the hit. Even where cars are not against or near the barrier, the Steward may still consider a hard t-bone anywhere on the circuit to be excessive and may take the appropriate action to discipline the driver.

- **You must take the green flag at the start or restart. If you fail to do so you cannot join the race thereafter. Penalties will be enforced if you break this rule.**

10. DEMOLITION - TYPE EVENTS

The following rules apply to any race where the nature of the event is to win by stopping the opposition. Demolition Derby Rules may only be used when the staging promoter declares (by way of a drivers briefing, letter, or notice on the programme) that these rules apply

- Attacking from the opposite direction is permitted, but no full length of the straight hits are permitted. No heavy t-bones are permitted.
- You may wait for a car or attack any part of the car except for the driver's area. This area is defined as being from the centre of the OSF wheel to the centre of the OSR door.
- Racing in the DD is optional, but if you do enter the DD the idea is to wreck your car by hitting the others.

11. ROLL BAR

1. Roll cages may be adjustable (height at the top of the cage and width), however the use of screw adjusters i.e. acrow style are not permitted. The roll cage must be fitted upright or dog-legged, but not leaning back or forward.
 - **It is compulsory to pad roll cages with seat foam, including the B pillar and steering columns must also be padded with seat foam.**

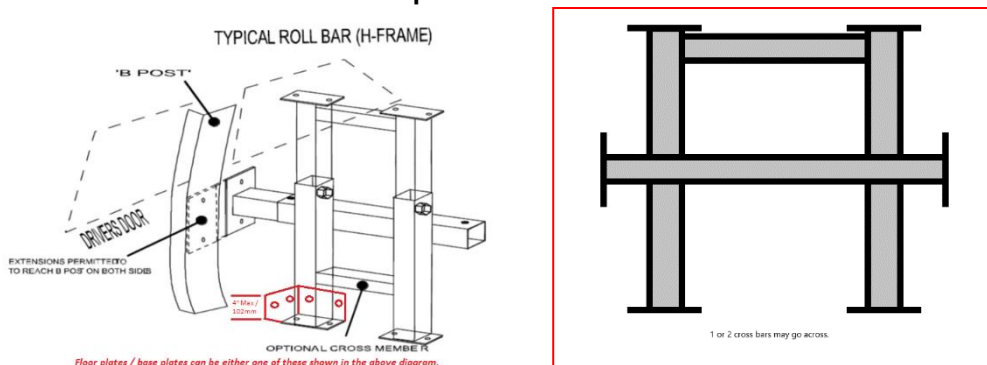

These two diagrams are a guideline to how the frame should be constructed but gusseting or triangulation is accepted.

- The hoop must be one piece or two uprights and one top bar of a welded construction. This top bar should be as shown at the top of the uprights.
- A second cross bar is compulsory, a third is optional; these must be welded or bolted to the uprights.
- THE ROLL BAR MUST NOT HAVE ANY REAR SUPPORTS but may have extensions no further forward than the B post (see diagram below).
- The minimum size for roll bar is 2"(50mm), maximum size 4"(100mm), minimum thickness 3mm. This MUST be box or tube.
- Crossbars must have a 5" (125mm) square end plate fitted.
- Each upright must have a minimum of two bolts on each side to the floor and two each side at the top. The maximum size of the base plate is 15" (385mm) x 11" (280mm) These may go up the side of the sill or the rear panel straight up and a maximum of 4" (102mm) high and the same length and width as the base plate/floor plate of the cage, a maximum of 2 bolts through the side.
- **Roll bar must be bolted in at the roof and floor with washers on the exterior of at least 100x100mm and not welded into the car at any point and must not protrude outside of the cars internal space.**
- **End plates of the roll cage must be bolted through the B pillar.**
- You must tie the seat at shoulder level to the roll cage or B pillar, through the seat frame not headrest, you may fit the 2nd cross bar in support of the seat just below the window aperture or weld a frame on the cage to support the seat at the top.

12. BODYWORK

- A driver's door plate must be fitted & overlap the door pillars by a minimum of 3".
- *NB. No trench plates are permitted.*
- The plate must be a minimum of 10mm or 3/8", to a maximum of 19mm or 3/4" in thickness.
- Its depth must be no less than 254mm or 10" & no more than 305mm or 12".
- The plate must have a minimum of five (M12) 19mm fixings. It must be through the 'B' Pillar, also the 'A' Pillar where possible with large washers each side.
- The door plate holes must not be slotted.
- A steel plate fitted to the driver's floor-pan is allowed. It must be no thicker than 6mm, and must be bolted in. This may be modified to rise to the maximum height of the sill of the door side only.
- Front wings maybe cut or trimmed but must not be crimped or folded.

Sun Roofs

- The glass must be removed and replaced with a piece of metal of a of 2mm, overlapping the aperture all the way round by 100mm or 4". The sunroof plate must not cover the top roll cage bolts. It must be securely fixed and can be welded. The fixing of this panel will have to meet the scrutineers approval.y67

13. WHEELS & TYRES

- Any standard manufactured road wheel may be used in any combination of sizes but this must not be used to gain an advantage.
- No tyre gators are permitted.
- Only conventional road tyres are allowed.
- A scrutineer has the option to ask the driver to remove any tyre they deem not within the spirit of the class.

14. EXHAUSTS

- Any car that is deemed to be too noisy will not be permitted to race. This is at the scrutineer and Steward of the Meetings discretion.
- Extra fittings are permitted.
- Ineffective or systems that become insecure while racing will require you to pull off the circuit, as you will be excluded from the results & get a technical disqualification.

15. BRAKES

- The standard manufacturers system must be used & work on all 4 wheels.
- The handbrake must also be operational.

16. FUEL SYSTEM

- The fuel tank must be made of steel or housed in a steel box & have a maximum capacity of 9 litres. No converted fire extinguishers are allowed.
- The fuel tank may be fitted to the "H frame" or behind the driver in the passenger area.
- Fuel caps must be of a metal screw type, no push fit types are allowed
- The fuel outlet must be from the top of the tank.
- A breather pipe must be fitted which must incorporate a one – way valve. The pipe must terminate through the floor as to prevent spillage if inverted.
- All fuel lines must be of good quality rubber or be metal covered, no rigid metal piping is allowed.
- Only roadside fuel can be used Petrol or Diesel. No additives are allowed.
- Multi point injection can be used with a return back to the tank or a t-piece fitted in the fuel line between the fuel tank and the fuel pump.

17. PAINTWORK

- The external appearance of the car must look bright & professional at all times; drivers of scruffy looking cars will be told to improve their appearance & may not be allowed to race.
- Sign writing must be approved by the Promoter.

18. SUN VISOR

- A Sun visor is not permitted.

19. FIN PLATES

- Fin plates must be fitted above the roof line & must not go past the back of the roof.
- Fin plate numbers must be 229mm or 9" high by 38mm or 1½" in width, plain black numbers on a plain white background only. Please ensure they are correct. No Holographic numbers or backgrounds.
- Damaged or unclear numbers may not be lap scored.
- The Fin plate must be mounted with a minimum of two M12 bolts, (No tex screws) the fin plate must be stood up and easily readable from a side view, if not you may not be lap scored. For 2025 you may add your name above the number but this must not interfere with the number.

20. DATA LOGGING

- No data logging is permitted.

21. VAN SPECIFICATIONS

- Upto 3.5tonne transit size, single wheel axle only. Diesel or petrol only.
- H-Frame or one acro behind the drivers seat in larger vans.
- No engine swaps permitted.
- No solid engine mountings.
- No tyre gators.
- Radiators must remain in the original position.
- All rear bumpers and tail lifts must be removed.
- Original front bumpers can be left in position.
- No adding of bumpers is permitted.
- All other 'Back To Basic' Banger rules apply unless specified for a special event via the promotion.
- No left-hand drive vehicles are permitted.

22. SPECIFICATION AND RULE CHANGES

The Promotion may at any time make amendments to the Specifications for the following reasons:

- In the interests of Safety
- Reduce costs for the driver
- In areas that are detrimental to the future of the formula
- If an unnecessary advantage has been deemed.
- A Scrutineer has the power to remove any item he/she may think is not within the spirit of the rules at the end of the meeting.

Current registered drivers will be notified automatically of any changes.

23. SEAT BELTS (Additional to ORCi documentation)

- Each Piece of Seatbelt must be fixed separately.
- If Chain is being used minimum size of chain is 8mm Diameter.

For further information contact :
Spedeworth House
Hollybush Industrial Park
Hollybush Lane
Aldershot
GU11 2PX
Tel : 01252 322 920
e-mail : info@spedeworth.co.uk

REVISED RULES FOR 2026 IN BOLD/ITALIC/RED PRINT
ITEMS MARKED ~~STRIKETHROUGH~~ ARE NO LONGER ALLOWED
2026 'Back to Basics' Bangers Technical Specifications
Issue 2, Dated 7th April 2026
These rules are to be enforced with immediate effect.